



marineusedgood

# Marine Anchor

website: [www.marineusedgood.com](http://www.marineusedgood.com)

Email: [info@marineusedgood.com](mailto:info@marineusedgood.com)





marineusedgood

**CJ-03** 丹福尔大抓力锚  
Danforth HHP ANCHOR

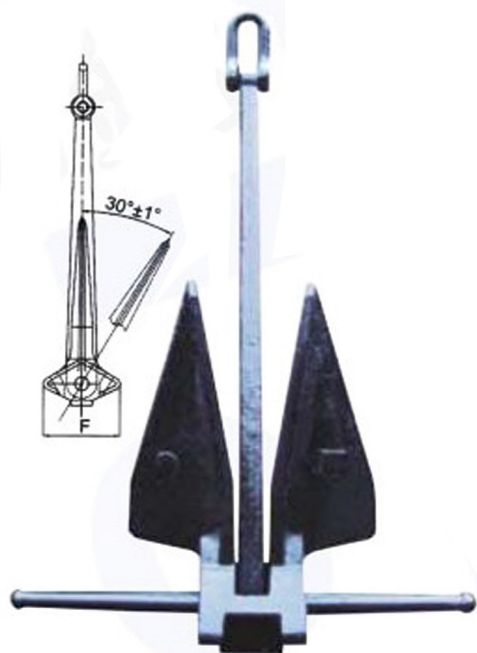
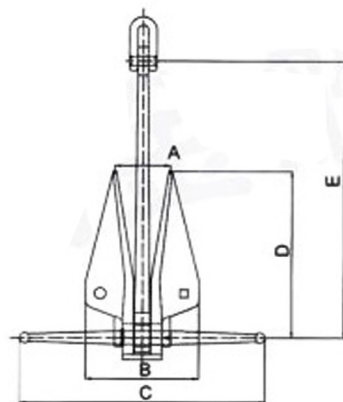

**CJ-04** CJD-14大抓力锚(德尔塔锚)  
CJD-14 HHP ANCHOR (Delta Anchor)

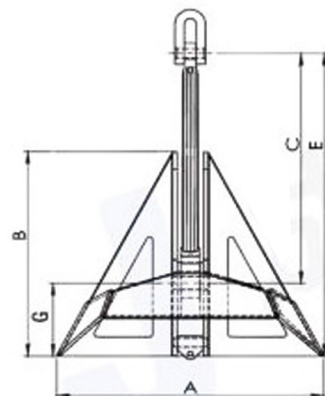

名义重量 NOMINAL WEIGHT (LBS)	尺寸SIZE (mm)						shackle model
	A	B	C	D	E	F	
100	159	322	714	485	800	219	a4
150	183	372	793	560	926	253	a5
200	203	412	874	621	995	281	a6
250	225	457	960	689	1075	312	a6
300	228	461	1000	706	1166	314	a7
400	257	522	1090	788	1284	356	a8
500	274	554	1180	836	1380	378	a9
600	290	588	1253	888	1466	401	a9
750	314	635	1350	958	1578	433	a9
1000	344	694	1488	1060	1739	472	a11
1250	367	741	1603	1135	1864	505	a12
1500	396	800	1703	1207	1988	545	a12
2000	438	888	1875	1336	2190	604	a14
2500	470	950	2020	1432	2300	647	a14
2625	470	950	2020	1432	2300	647	a14
2750	485	960	2120	1432	2335	650	a14

名义重量 NOMINAL WEIGHT (LBS)	尺寸SIZE (mm)						shackle model
	A	B	C	D	E	F	
3000	502	1033	2146	1575	2396	710	a14
3500	550	1111	2265	1677	2515	757	a15
4000	552	1114	2365	1680	2623	759	a15
5000	595	1200	2480	1811	2850	818	a16
6000	630	1274	2680	1920	3164	866	a17
6600	652	1317	2792	1986	3260	897	a19
8000	692	1398	2970	2109	3475	971	a19
9000	715	1448	3080	2200	3490	990	a20
10000	735	1484	3200	2270	3591	1010	a21
15000	851	1700	3680	2610	4100	1160	a23
20000	936	1870	4050	2870	4510	1276	a26
30000	1136	2250	4900	3400	5400	1520	a30
35000	1208	2414	5250	3670	5830	1642	a31
40000	1286	2588	5625	3930	6250	1758	a32
45000	1378	2745	5968	4172	6610	1867	a33
50000	1450	2890	6282	4393	6950	1965	a34

名义重量 NOMINAL WEIGHT	尺寸SIZE (mm)					
	A	B	C	D	E	F
300	1200	960	1080	457	1380	45
500	1500	1200	1350	571	1725	50
750	1780	1400	1600	665	2110	510
1000	1875	1500	1686	714	2155	62
1500	2250	1800	2024	840	2677	68
2000	2363	1890	2124	900	2715	82
2500	2540	2030	2280	965	2880	82
3000	2700	2160	2430	1028	3105	90
4000	2975	2380	2650	1130	3395	100
5000	3250	2600	2922	1238	3735	110
6000	3450	2760	3060	1316	3923	110
7000	3575	2860	3216	1361	4116	117
7500	3650	2925	3290	1390	4210	117
8000	3730	2990	3360	1420	4300	130
9000	3950	3160	3555	1504	4513	135
10000	4100	3280	3690	1561	4715	140
12000	4300	3440	3942	1638	5017	145
13500	4670	3720	4195	1765	5535	150
15000	4845	3875	4355	1830	5513	150

名义重量 NOMINAL WEIGHT	尺寸SIZE (mm)					
	A	B	C	D	E	F
18000	5140	4080	4610	1940	6080	160
20000	5330	4260	4790	2010	6310	170
22500	5490	4360	4905	2060	6470	180
25000	5740	4590	5160	2165	6532	195
30000	6100	4880	5486	2305	7225	195
35000	6424	5138	5775	2426	7605	205
40000	6715	5370	6036	2536	7948	210
45000	6986	5588	6184	2640	8270	220
50000	7230	5785	6500	2730	8560	225
55000	7470	5975	6715	2820	8840	230
60000	7690	6150	6910	2940	9100	240
65000	7900	6315	7100	2980	9350	245
70000	8095	6475	7275	3060	9580	250
75000	8235	6590	7405	3110	9750	255
80000	8460	6770	7610	3195	10020	260
85000	8625	6900	7750	3255	10210	265
90000	8800	7040	7910	3325	10420	270
95000	8960	7170	8055	3385	10610	280
100000	9110	7285	8190	3440	10780	280



marineusedgood

### CJ-20 CJT-20大抓力锚(TW波尔锚) CJT-20 HHP ANCHOR(POOL ANCHOR TYPE tw)

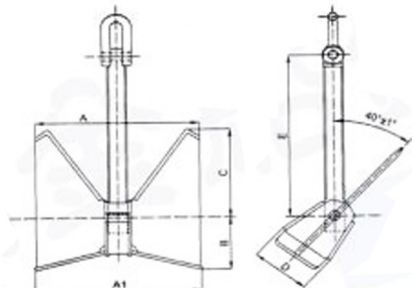

名义重量 NOMINAL WEIGHT (KG)	尺寸SIZE (mm)						Shackle Model	名义重量 NOMINAL WEIGHT (KG)	尺寸SIZE (mm)						Shackle Model
	A	A1	B	C	D	E			A	A1	B	C	D	E	
105	640	650	250	422	240	705	a6	4500	2264	2297	861	1510	854	2740	a20
135	696	706	273	460	262	815	a6	4840	2316	2349	879	1543	868	2900	a21
160	736	746	289	486	277	895	a7	5175	2334	2367	889	1558	876	2829	a22
180	766	776	300	506	288	937	a7	5250	2363	2397	926	1558	887	2870	a22
225	825	837	324	545	310	982	a8	5515	2412	2446	926	1608	911	2921	a22
270	877	890	344	579	329	1080	a8	5850	2450	2485	960	1615	920	2985	a23
300	907	922	356	600	340	1080	a8	6225	2509	2543	980	1640	940	3033	a23
360	965	980	378	638	362	1175	a9	6975	2623	2659	1015	1707	990	3145	a23
430	1024	1040	402	676	384	1200	a9	7875	2695	2735	1050	1773	1012	3264	a24
495	1074	1090	420	709	402	1257	a10	8148	2744	2771	1067	1805	1030	3320	a24
565	1122	1138	440	740	436	1318	a11	8420	2794	2822	1087	1838	1049	3381	a24
675	1205	1221	475	801	454	1456	a11	8710	2823	2851	1098	1857	1060	3416	a25
765	1256	1272	476	836	455	1518	a12	9000	2852	2881	1109	1876	1071	3451	a25
855	1306	1327	494	866	496	1575	a13	9340	2885	2914	1122	1898	1083	3491	a25
970	1360	1381	532	896	513	1642	a13	9680	2918	2947	1135	1919	1096	3531	a26
1080	1410	1431	540	910	536	1703	a13	10090	2947	2976	1146	1939	1107	3566	a26
1195	1435	1446	545	955	537	1730	a13	10500	2977	3007	1158	1958	1118	3602	a26
1305	1490	1512	580	981	558	1814	a14	10765	3008	3038	1170	1979	1130	3640	a26
1440	1554	1576	587	1031	585	1875	a14	11030	3039	3069	1182	1999	1141	3677	a27
1575	1594	1618	606	1062	600	1931	a14	11365	3063	3094	1192	2015	1150	3706	a27
1710	1635	1659	622	1092	614	1985	a15	11100	3087	3118	1201	2031	1159	3735	a27
1845	1684	1709	638	1120	638	2035	a15	12075	3124	3155	1215	2055	1173	3780	a28
1980	1733	1758	657	1153	654	2088	a15	12450	3161	3193	1230	2079	1187	3825	a28
2140	1765	1803	671	1177	664	2138	a16	13200	3233	3265	1258	2127	1214	3912	a29
2295	1802	1829	686	1205	678	2190	a16	13950	3305	3338	1286	2174	1241	3999	a29
2475	1860	1887	704	1236	705	2240	a17	14850	3350	3384	1303	2204	1258	4054	a30
2655	1900	1927	720	1263	716	2298	a17	15750	3395	3429	1321	2233	1275	4108	a30
2835	1945	1973	737	1294	730	2350	a17	16295	3457	3492	1345	2274	1298	4183	a31
3040	1984	2012	754	1324	744	2404	a17	16840	3520	3555	1369	2315	1322	4259	a31
3240	2036	2066	770	1351	768	2456	a18	17420	3556	3592	1383	2339	1335	4303	a32
3445	2070	2100	789	1381	782	2507	a18	18000	3593	3629	1398	2363	1349	4348	a32
3670	2110	2142	804	1410	795	2560	a19	18680	3634	3670	1414	2390	1365	4397	a32
3940	2152	2185	820	1440	802	2621	a19	19360	3676	3713	1430	2418	1380	4448	a33
4210	2218	2251	842	1478	838	2680	a20	20000	3713	3750	1444	2442	1394	4493	a33

### CJ-17 CJ-17大抓力锚(海工锚) CJ-17 HHP ANCHOR (OFFSHORE ANCHOR)

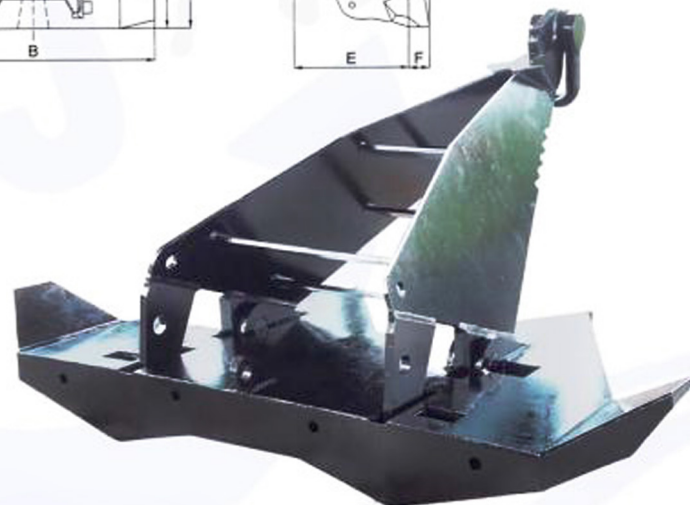
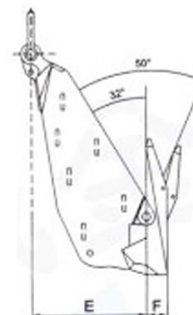
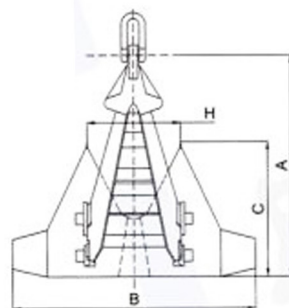

名义重量 NOMINAL WEIGHT (KG)	尺寸SIZE (mm)					
	A	B	C	E	F	H
300	1828	1968	1101	927	160	757
500	2040	2197	1233	1035	179	845
1000	2570	2770	1562	1304	226	1064
1500	2944	3174	1802	1495	261	1230
2000	3244	3494	1969	1646	285	1343
3000	3711	4001	2279	1886	332	1540
4000	4083	4403	2431	2074	359	1692
5000	4402	4746	2607	2238	396	1835
6000	4690	5040	2841	2374	411	1988
7000	4900	5280	3001	2490	443	2045
8000	5151	5553	3156	2619	464	2139

名义重量 NOMINAL WEIGHT (KG)	尺寸SIZE (mm)					
	A	B	C	E	F	H
9000	5359	5772	3253	2719	471	2219
10000	5549	5932	3400	2822	501	2305
12000	5893	6353	3614	3000	533	2450
14000	6209	6694	3805	3159	562	2580
15000	6354	6850	3804	3232	575	2640
16000	6469	6967	3927	3282	589	2673
18000	6753	7280	4139	3436	612	2806
20000	6994	7540	4287	3559	634	2907
22000	7220	7784	4426	3674	654	3001
25000	7535	8123	4619	3834	684	3132
30000	8003	8635	4919	4075	727	3329



marineusedgood

### CJ-22 N型 波尔锚 POOL HHP ANCHOR TYPE N

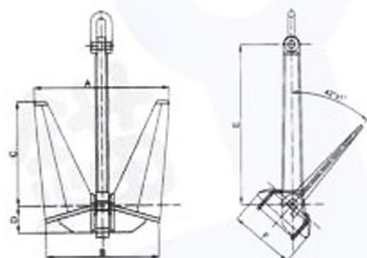

名义重量 NOMINAL WEIGHT (KG)	尺寸SIZE (mm)					
	A	B	C	D	E	F
12	323	275	250	65	383	155
20	386	325	300	75	458	185
25	409	350	316	80	485	200
40	479	410	370	95	567	235
50	517	440	400	100	613	255
60	550	470	425	110	652	270
80	608	515	470	120	720	295
100	653	555	505	130	775	320
120	699	595	540	135	825	340
135	723	614	562	139	858	342
160	764	650	590	150	905	370
180	795	675	615	155	940	385
640	825	700	640	160	978	400
225	858	729	666	165	1016	406
240	880	745	680	175	1040	425
280	925	780	715	180	1092	450
320	964	820	745	190	1140	470
360	1005	855	780	195	1190	490
400	1040	885	805	205	1230	505
440	1074	910	830	210	1270	520
480	1105	940	855	215	1305	535
520	1133	960	875	220	1340	550
560	1165	985	900	230	1375	565
600	1191	1010	920	235	1410	580
640	1217	1035	940	240	1440	675
675	1237	1051	960	245	1464	585
720	1262	1075	975	250	1495	615
800	1310	1115	1015	255	1550	635
855	1338	1137	1039	257	1585	633
900	1365	1160	1055	270	1615	665
970	1396	1186	1084	272	1654	660
1000	1410	1200	1090	275	1670	670
1080	1447	1229	1123	278	1713	684
1250	1521	1290	1175	300	1800	740
1305	1541	1309	1196	296	1824	729
1500	1615	1370	1250	315	1910	785
1575	1641	1394	1274	315	1943	776
1750	1705	1445	1320	335	2015	830
1845	1729	1469	1343	340	2049	818
2000	1780	1510	1375	350	2105	865

名义重量 NOMINAL WEIGHT (KG)	尺寸SIZE (mm)					
	A	B	C	D	E	F
2140	1817	1544	1411	349	2152	860
2250	1850	1570	1430	360	2185	900
2500	1920	1630	1480	375	2265	930
2655	1954	1664	1516	372	2312	925
2835	1996	1700	1550	380	2364	945
3040	2042	1735	1585	390	2418	968
3240	2086	1773	1620	398	2471	988
3445	2129	1809	1653	406	2522	1009
3670	2174	1847	1689	415	2576	1030
3940	2226	1892	1730	425	2640	1055
4210	2276	1934	1768	434	2698	1078
4500	2328	1978	1808	444	2758	1103
4840	2385	2026	1852	455	2825	1130
5175	2439	2072	1894	465	2889	1155
5515	2491	2116	1934	475	2950	1180
5850	2541	2159	1973	485	3009	1204
6225	2594	2204	2014	495	3072	1229
6525	2635	2239	2046	503	3121	1248
6975	2695	2290	2092	514	3191	1276
7425	2751	2337	2136	525	3258	1303
7875	2805	2384	2178	535	3323	1329
8325	2858	2428	2219	545	3385	1354
8775	2908	2471	2258	555	3445	1378
9225	2958	2512	2296	564	3502	1401
9675	3004	2553	2333	573	3558	1423
10215	3050	2592	2369	582	3613	1445
10575	3095	2630	2403	590	3666	1466
11025	3138	2667	2437	599	3717	1486
11550	3187	2708	2475	608	3775	1510
12075	3235	2748	2512	617	3831	1533
12675	3288	2794	2553	628	3894	1557
13350	3345	2842	2598	638	3962	1585
14100	3406	2895	2645	649	4035	1614
15000	3478	2955	2700	664	4119	1647
15400	3508	2981	2724	669	4155	1662
16125	3563	3027	2766	680	4220	1687
17250	3643	3096	2829	696	4315	1726
18375	3712	3162	2889	710	4407	1762
19500	3795	3225	2947	725	4495	1798
20625	3867	3286	3003	738	4580	1832

### CJN平衡大抓力锚 CJN-SB TYPE HHP ANCHOR CJ-23

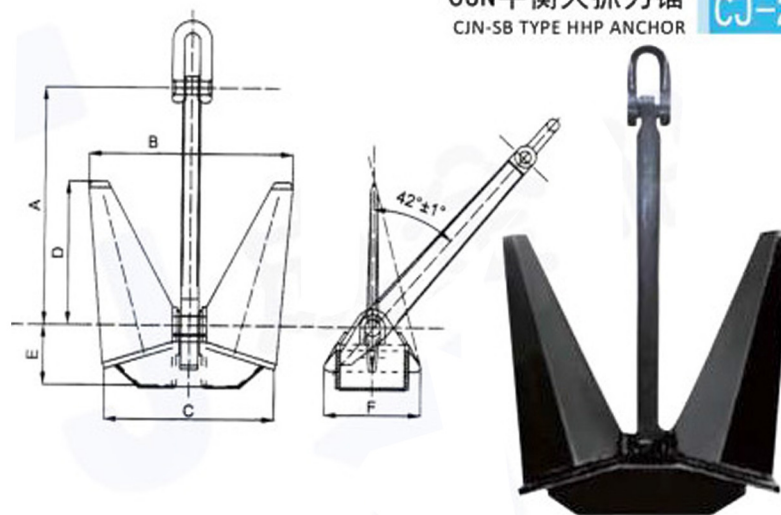

名义重量 NOMINAL WEIGHT (KG)	尺寸SIZE (mm)					
	A	B	C	D	E	F
60	590	555	470	364	157	270
80	664	605	515	410	176	295
100	712	655	555	440	190	320
160	835	765	650	516	223	370
200	885	825	700	546	236	400
280	1008	925	780	622	269	450
360	1096	1005	855	677	292	490
480	1186	1105	940	728	314	535
600	1300	1190	1010	802	347	580
765	1410	1290	1096	870	375	610
1000	1526	1395	1185	942	404	660
1080	1580	1446	1230	975	421	685
1195	1636	1485	1270	1010	436	708
1305	1680	1541	1308	1037	448	730
1440	1738	1592	1352	1073	464	754
1575	1769	1640	1386	1092	472	777
1710	1840	1686	1455	1137	491	798
1845	1890	1729	1469	1168	504	819
1980	1935	1770	1504	1195	516	836
2140	1985	1816	1543	1226	530	860
2295	2030	1860	1580	1254	540	880
2655	2140	1954	1684	1322	566	926
2835	2188	1996	1700	1351	580	945
3000	2238	2042	1736	1382	592	968
3240	2287	2086	1773	1412	605	988

名义重量 NOMINAL WEIGHT (KG)	尺寸SIZE (mm)					
	A	B	C	D	E	F
3940	2442	2226	1892	1508	646	1055
4500	2553	2328	1976	1576	675	1103
5175	2675	2439	2072	1651	708	1155
5515	2730	2491	2116	1686	722	1180
5850	2786	2541	2159	1720	737	1204
6225	2838	2594	2204	1750	756	1229
6525	2880	2635	2239	1780	768	1248
6975	2948	2695	2290	1820	786	1276
7425	3010	2760	2338	1858	802	1303
7875	3069	2805	2384	1895	818	1329
8325	3180	2908	2471	1964	848	1376
8775	3235	2968	2512	1997	862	1401
9225	3286	3004	2553	2029	876	1423
9675	3337	3060	2592	2060	890	1445
10125	3386	3095	2630	2090	902	1468
10575	3438	3236	2748	2184	943	1533
12675	3596	3288	2794	2220	958	1556
13350	3658	3346	2842	2258	975	1585
14100	3726	3406	2894	2300	993	1614
15000	3804	3476	2954	2348	1014	1646
17250	3985	3643	3095	2460	1062	1726
20825	4240	3887	3285	2618	1130	1832
24750	4495	4109	3491	2775	1198	1947
28875	4717	4324	3675	2912	1258	2049



marineusedgood

### CJ-05 斯贝克锚 CB711-95 SPEK ANCHOR

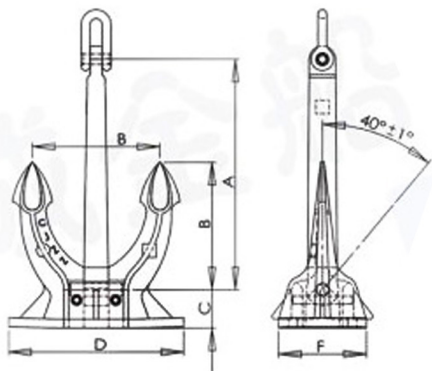

名义重量 NOMINAL WEIGHT (KG)	尺寸SIZE (mm)				
	A	B	C	D	F
100	672	373	112	515	250
150	770	428	128	590	290
180	846	470	140	640	300
240	900	500	150	690	358
300	990	550	166	760	398
360	1065	600	180	828	411
420	1080	600	180	828	431
500	1170	650	196	900	450
570	1170	650	196	900	475
660	1260	700	210	960	486
780	1355	750	225	1032	519
900	1440	800	240	1100	547
1020	1530	850	252	1170	573
1140	1620	900	268	1240	591
1290	1710	900	268	1240	620
1440	1710	950	279	1300	640
1590	1710	950	279	1300	671
1740	1800	1000	300	1378	689
1920	1850	1050	312	1454	704
2100	1890	1050	312	1454	717
2280	2010	1050	312	1454	736
2460	2010	1100	324	1514	764
2640	2070	1150	352	1584	794
2850	2070	1150	352	1584	804
3060	2160	1200	360	1650	820
3300	2155	1200	360	1650	834
3540	2350	1200	360	1650	834
3780	2430	1350	393	1850	880
4050	2430	1350	393	1850	917

名义重量 NOMINAL WEIGHT (KG)	尺寸SIZE (mm)				
	A	B	C	D	F
4320	2520	1400	413	1926	917
4590	2520	1400	413	1926	951
4890	2520	1400	413	1926	954
5250	2610	1450	414	2000	964
5610	2610	1450	414	2000	981
6000	2700	1500	446	2060	1006
6450	2700	1500	446	2060	1028
6900	2790	1550	456	2138	1034
7350	2790	1550	456	2138	1062
7800	2920	1550	456	2138	1091
8300	3060	1700	510	2332	1126
8700	3060	1700	510	2332	1156
9300	3060	1700	510	2332	1169
9900	3160	1700	510	2332	1188
10500	3190	1770	531	2440	1188
11100	3290	1770	531	2440	1212
11700	3390	1770	531	2440	1237
12300	3440	1910	573	2632	1279
12900	3440	1910	573	2632	1279
13500	3440	1910	573	2632	1316
14100	3440	1910	573	2632	1353
14700	3690	2050	615	2824	1369
15400	3690	2050	615	2824	1369
16100	3690	2050	615	2824	1387
16900	3820	2120	636	2922	1415
17800	3950	2120	636	2922	1431
18800	3950	2190	657	3018	1461
20000	4070	2190	657	3018	1493
26000	4250	2360	716	3256	1618

### M型 斯贝克锚 CJ-06 TYPE M SPEK ANCHOR

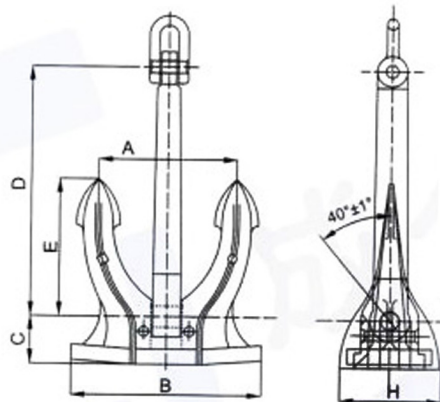

名义重量 NOMINAL WEIGHT (KG)	尺寸SIZE (mm)					
	A	B	C	D	E	H
80	339	468	108	611	336	222
105	371	512	120	669	336	242
135	371	512	149	669	368	254
240	445	613	182	800	440	304
300	527	727	168	949	522	344
360	527	727	190	949	522	358
420	590	813	188	1062	584	385
480	590	813	211	1062	584	395
570	652	900	208	1175	647	428
660	653	900	208	1175	647	428
780	725	1000	231	1305	718	473
900	725	1000	264	1215	718	485
1020	793	1093	252	1428	785	518
1140	793	1093	277	1428	785	530
1290	858	1183	273	1544	850	561
1440	858	1183	299	1544	850	573
1590	920	1268	293	1655	911	604
1740	920	1268	315	1655	911	611
1920	980	1350	312	1761	970	640
2100	980	1350	337	1761	970	650
2280	1038	1430	331	1866	1027	678
2460	1038	1430	355	1866	1027	688
2640	1090	1500	347	1959	1079	712
2850	1190	1500	380	1950	1079	722
3060	1144	1578	365	2058	1133	748
3300	1144	1578	387	2058	1133	760
3540	1202	1656	383	2159	1189	785
3780	1202	1656	405	2159	1189	797
4050	1257	1732	400	2258	1244	821

名义重量 NOMINAL WEIGHT (KG)	尺寸SIZE (mm)					
	A	B	C	D	E	H
4320	1257	1732	422	2258	1244	831
4590	1257	1732	444	2258	1244	841
4890	1338	1846	426	2405	1325	874
5250	1338	1846	450	2405	1325	888
5610	1432	1974	431	2405	1418	936
6000	1432	1974	457	2577	1418	936
6450	1432	1974	483	2577	1418	950
6900	1533	2112	462	2757	1518	1001
7350	1533	2112	488	2757	1518	1001
7800	1533	2112	514	2757	1518	1015
8300	1621	2234	489	2916	1605	1059
8700	1621	2234	517	2916	1605	1059
9300	1621	2234	545	2916	1605	1074
9900	1726	2380	520	3015	1709	1128
10500	1726	2380	550	3105	1709	1128
11100	1726	2380	580	3105	1709	1138
11700	1819	2507	554	3273	1801	1188
12300	1819	2507	580	3273	1801	1188
12900	1819	2507	607	3273	1801	1200
13500	1904	2624	577	3425	1885	1243
14100	1904	2624	607	3425	1885	1243
14700	1904	2624	650	3425	1885	1243
15400	1904	2624	657	3425	1885	1263
16100	2018	2782	612	3632	1998	1318
16900	2018	2782	638	3632	1998	1318
17800	2018	2782	683	3632	1998	1318
18800	2018	2782	699	3632	1998	1343
20000	2170	2990	652	3905	2148	1416



marineusedgood

**CJ-07** SR型 斯贝克锚  
TYPE SR SPEK ANCHOR

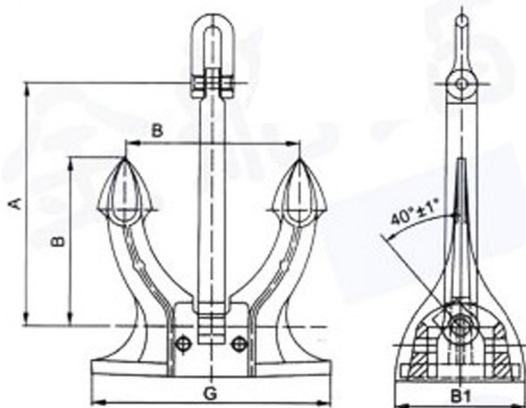

名义重量 NOMINAL WEIGHT (KG)	尺寸 SIZE (mm)			
	A	B	B1	G
210	900	500	340	690
240	900	550	390	760
300	1080	600	412	828
420	1080	600	412	828
450	1080	600	412	828
480	1170	650	442	900
570	1170	650	442	900
610	1260	700	472	962
660	1260	700	472	962
750	1350	750	508	1032
780	1350	750	519	1032
900	1440	800	547	1100
980	1440	800	547	1100
1020	1530	850	573	1170
1040	1620	900	591	1240
1100	1620	900	620	1240
1200	1710	950	640	1300
1300	1710	950	640	1300
1400	1710	950	671	1300
1500	1710	9500	671	1300
1650	1800	1000	669	1378
1800	1890	1050	704	1454
1920	1890	1050	717	1454
2100	1890	1050	736	1454
2190	1890	1050	736	1454
2280	1980	1100	764	1454
2460	2070	1150	794	1584
2640	2070	1150	804	1584
2850	2160	1200	812	1650
3300	2160	1200	834	1650

名义重量 NOMINAL WEIGHT (KG)	尺寸 SIZE (mm)			
	A	B	B1	G
3540	2160	1200	834	1650
3780	2430	1350	880	1850
4050	2430	1350	914	1850
4320	2520	1400	917	1926
4590	2520	1400	931	1926
4890	2520	1400	954	1926
5250	2610	1450	964	2000
5610	2610	1450	981	2000
5800	2700	1500	1006	2060
6000	2700	1500	1006	2060
6450	2700	1500	1023	2060
6900	2790	1550	1034	2138
7350	2790	1550	1062	2138
7800	2790	1550	1091	2138
8000	2790	1550	1091	2138
8300	3060	1700	1125	2332
8700	3060	1700	1166	2332
9300	3060	1700	1188	2332
9900	3060	1700	1188	2332
10500	3186	1770	1197	2440
11100	3186	1770	1212	2440
11700	3186	1770	1237	2440
12300	3438	1910	1260	2632
12900	3438	1910	1260	2632
13500	3438	1910	1316	2632
14700	3690	2050	1369	2824
16900	3816	2120	1415	2922
18800	3942	2190	1461	3018
20000	3942	2190	1493	3018

海军锚 **CJ-08**

GB/T545-1996 ADMIRALTY ANCHOR



名义重量 NOMINAL WEIGHT (KG)	尺寸 SIZE (mm)				
	H	h	h1	B	C
50	960	230	42	635	185
75	1105	266	45	710	210
100	1215	293	49	780	230
125	1310	316	52	840	245
150	1395	336	55	900	265
200	1535	370	61	990	290
250	1650	398	65	1065	310
300	1755	423	70	1105	330
400	1930	465	77	1240	365
500	2080	502	84	1335	390

名义重量 NOMINAL WEIGHT (KG)	尺寸 SIZE (mm)				
	H	h	h1	B	C
600	2210	533	89	1440	415
700	2330	560	93	1500	440
800	2435	587	97	1570	460
900	2530	610	101	1630	475
1000	2620	633	104	1685	495
1250	2825	680	112	1810	535
1500	3000	725	118	1955	565
2000	3300	797	131	2140	625
2500	3550	857	138	2270	672
3000	3780	912	150	2415	715
3500	3980	960	158	2540	750
4000	4160	1000	155	2650	785
5000	4480	1100	184	2830	800
6000	4740	1113	190	3000	438
7000	5025	1180	200	3165	960
8000	5240	1280	210	3300	980
9000	5450	1330	220	3440	990
10000	5680	1340	230	3600	1085

单爪锚 **CJ-09**

SINGLE FIUKE ANCHOR

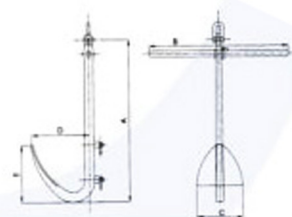

名义重量 NOMINAL WEIGHT (KG)	尺寸 SIZE (mm)				
	A	B	C	D	E
75	1310	1100	360	455	465
100	1445	1200	400	500	510
150	1650	1380	455	575	585
200	1820	1520	505	630	645
300	2080	1740	575	725	735
400	2290	1915	635	800	810
500	2470	2065	680	855	875
600	2620	2190	725	910	930
800	2890	2415	800	1000	1020
1000	3110	2600	860	1080	1100
1250	3350	2800	925	1165	1185
1500	3560	2980	985	1235	1260
1750	3750	3135	1035	1300	1325
2000	3920	3275	1085	1360	1385

名义重量 NOMINAL WEIGHT (KG)	尺寸 SIZE (mm)				
	A	B	C	D	E
3000	4485	3750	1240	1555	1585
4000	4940	4125	1360	1710	1745
5000	5320	4440	1472	1845	1880
6000	5650	4720	1560	1960	1995
7000	5950	4970	1645	2065	2100
8000	6220	5200	1720	2155	2200
9000	6468	5400	1790	2240	2288
10000	6700	5600	1852	2320	2354
12000	7115	5950	1968	2465	2516
15000	7670	6410	2120	2657	2710
18000	8148	6810	2253	2823	2882
20000	8400	7020	2320	2910	2970
22000	8710	7275	2410	3020	3074
25000	9080	7590	2510	3146	3212



marineusedgood

**CJ-10** A、B、C型 霍尔锚  
TYPE A,B,C HALL ANCHOR

名义重量 NOMINAL WEIGHT (KG)	尺寸SIZE (mm)							
	H			h	h1	L	L1	B1
	A型	B型	C型					
40	557	557	430	303	67	430	303	198
60	637	637	492	347	76	492	347	227
100	760	760	590	410	90	584	410	227
125	814	814	629	443	97	629	443	290
150	866	866	665	470	103	760	470	308
180	919	919	718	500	109	710	500	327
240	1019	1019	788	552	120	790	552	361
300	1095	1095	850	595	130	844	595	388
360	1160	1160	898	630	138	898	630	412
420	1160	1160	946	660	145	946	660	434
480	1222	1222	986	690	152	988	690	454
570	1355	1355	1042	732	161	1042	732	481
660	1356	1356	1093	769	169	1096	769	506
780	1506	1506	1170	813	178	1160	813	535
900	1580	1580	1215	855	188	1220	855	560
1020	1645	1645	1268	855	188	1220	855	560
1140	1705	1705	1316	926	203	1319	926	605
1290	1778	1778	1378	891	195	1268	891	584
1440	1844	1844	1448	965	203	1379	965	630
1590	1906	1906	1511	1035	226	1475	1035	677
1740	1966	1966	1571	1068	234	1517	1068	698
1920	2031	2031	1602	1104	241	1568	1104	722
2100	2093	2093	1651	1120	245	1560	1120	732
2280	2150	2150	1716	1165	225	1657	1165	763
2460	2207	2207	1785	1194	262	1700	1194	784
2640	2259	2259	1843	1222	265	1730	1222	796
2850	2318	2318	1890	1253	275	1787	1253	822
3060	2374	2374	1935	1283	282	1832	1283	841
3300	2432	2432	1985	1317	288	1880	1317	862
3540	2490	2490	2032	1349	295	1926	1394	883
3780	2547	2547	2077	1376	302	1965	1376	902
4050	2610	2610	2125	1406	309	2008	1406	924
4320	2695	2695	2171	1435	316	2051	1435	943
4590	2712	2712	2216	1465	332	2093	1465	962
4890	2769	2769	2263	1498	329	2135	1498	984
5000	2800	2800	2317	1510	332	2156	1510	992
5610	2899	2899	2369	1569	345	2234	1569	1031
6000	2965	2965	2422	1605	352	2284	1605	1054
6450	3037	3037	2482	1644	361	2340	1644	1080
6900	3100	3100	2538	1681	369	2393	1681	1105
7350	3100	3100	2592	1688	370	2400	1688	1109
7800	3235	3235	2644	1752	385	2493	1752	1152
8300	3363	3363	2699	1788	393	2545	1788	1176

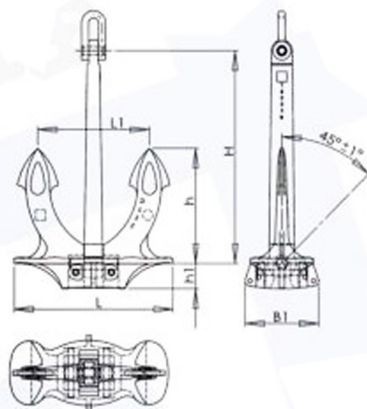

Type A Hall Anchor



Type B Hall Anchor

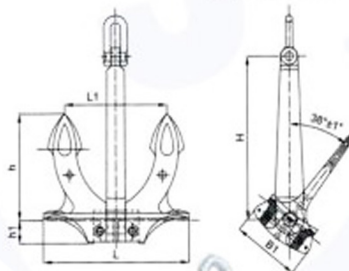

Type C Hall Anchor

A、B、C型 霍尔锚 **CJ-10**  
TYPE A,B,C HALL ANCHOR

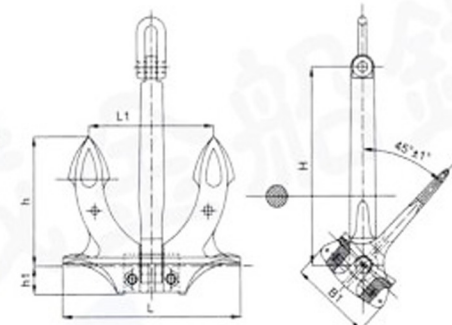

名义重量 NOMINAL WEIGHT (KG)	尺寸SIZE (mm)							
	H			h	h1	L	L1	B1
	A型	B型	C型					
8700	3355	3355	2742	1816	399	2585	1816	1195
9300	3430	3430	2804	1850	417	2632	1850	1226
9900	3502	3502	2863	1896	417	2699	1896	1248
10500	3571	3571	2920	1934	425	2752	1934	1273
11100	3638	3638	2975	1970	433	2803	1970	1297
11700	3702	3702	3028	2005	441	2853	2005	1320
12300	3764	3764	3079	2039	448	2901	2039	1342
12900	3824	3824	3128	2072	455	2947	2072	1363
13500	3882	3882	3176	2104	462	2992	2104	1384
14100	3939	3939	3222	2135	469	3036	2135	1404
14700	3994	3994	3267	2165	476	3078	2165	1424
15400	4056	4056	3318	2199	483	3126	2199	1446
16100	4117	4117	3368	2232	490	3173	2232	1468
16900	4184	4184	3423	2268	498	3225	2268	1492
17800	4252	4252	3479	2308	506	3281	2308	1518
18800	4330	4330	3543	2350	516	3341	2350	1546
20000	4420	4420	3617	2399	526	3411	2399	1578
21500	4528	4528	3705	2458	539	3494	2458	1617
23000	4631	4631	3789	2514	551	3573	2514	1654
24500	4730	4730	3870	2568	563	3649	2568	1689
26000	4825	4825	3947	2619	574	3722	2619	1723
27500	4916	4916	4021	2668	585	3792	2668	1756
29000	5004	5004	4093	2716	595	3860	2716	1787
31000	5126	5126	4188	2774	609	3949	2774	1822
33000	5234	5234	4276	2833	622	4032	2833	1860
35500	5363	5363	4381	2903	637	4132	2903	1906
38500	5510	5510	4502	2982	655	4245	2982	1958
42000	5672	5672	4634	3070	674	4370	3070	2015
46000	5847	5847	4777	3165	695	4505	3165	2078



marineusedgood

**CJ-11 日本无杆锚**  
JAPAN STOCKLESS ANCHOR

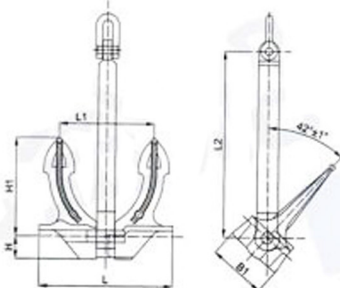

名义重量 NOMINAL WEIGHT (KG)	尺寸SIZE (mm)					
	L	L1	L2	H	H1	B1
180	650	459	910	111	480	280
240	720	510	1010	122	530	310
300	770	540	1080	131	570	331
360	820	580	1150	139	610	353
420	860	610	1200	146	640	370
480	900	640	1260	153	670	387
570	950	670	1330	162	700	408
660	1000	710	1440	170	740	430
780	1060	750	1480	180	780	456
900	1110	780	1550	189	820	477
1020	1160	820	1620	197	860	500
1140	1200	850	1680	204	890	520
1290	1250	880	1750	212	920	540
1440	1300	920	1820	221	960	560
1590	1340	950	1880	228	990	580
1740	1380	980	1930	235	1020	600
1920	1430	1010	2000	243	1060	620
2100	1470	1040	2060	250	1090	640
2280	1510	1070	2110	257	1120	650
2460	1550	1100	2170	264	1150	670
2640	1590	1120	2230	270	1180	690
2850	1630	1150	2280	277	1210	700
3060	1670	1180	2340	284	1240	720
3300	1710	1210	2390	291	1270	740
3540	1750	1240	2450	298	1290	750
3780	1790	1260	2510	304	1320	770
4050	1830	1290	2560	311	1350	790
4320	1870	1320	2620	318	1380	800
4590	1910	1350	2670	325	1410	820
4890	1950	1380	2730	332	1440	840
5250	2000	1410	2800	340	1480	860
5610	2040	1440	2860	347	1510	880
6000	2090	1480	2930	355	1540	900

名义重量 NOMINAL WEIGHT (KG)	尺寸SIZE (mm)					
	L	L1	L2	H	H1	B1
6450	2140	1510	3000	364	1580	920
6900	2190	1550	3070	372	1620	940
7350	2240	1600	3140	380	1660	960
7800	2280	1610	3190	388	1680	980
8300	2330	1650	3260	396	1720	1000
8700	2380	1670	3320	403	1750	1020
9300	2420	1710	3390	411	1790	1040
9900	2470	1740	3460	420	1820	1060
10500	2520	1800	3530	428	1880	1090
11100	2570	1800	3600	437	1880	1090
11700	2610	1855	3650	444	1945	1130
12300	2650	1855	3710	450	1945	1130
12900	2690	1885	3870	457	1975	1170
13500	2740	1885	3840	466	1975	1170
14100	2780	1960	3890	473	2050	1200
14700	2820	1990	3950	479	2080	1210
15400	2860	2020	4000	486	2110	1230
16100	2900	2050	4060	493	2140	1250
16900	2955	2080	4130	500	2180	1270
17800	3000	2120	4200	510	2210	1290
18800	3060	2160	4280	520	2260	1320
20000	3120	2200	4370	530	2300	1340
21500	3200	2260	4480	540	2360	1380
23000	3270	2310	4580	560	2410	1410
24500	3340	2360	4680	570	2460	1440
26000	3410	2410	4770	580	2520	1470
27500	3470	2450	4860	590	2560	1490
29000	3530	2490	4940	600	2660	1550
33000	3690	2610	5170	630	2720	1590
35500	3780	2670	5290	640	2790	1630
38500	3880	2740	5430	660	2860	1670
42000	4000	2820	5600	680	2950	1720
46000	4120	2910	5770	700	3040	1770

**日本有杆锚 CJ-12**  
JAPAN STOCK ANCHOR

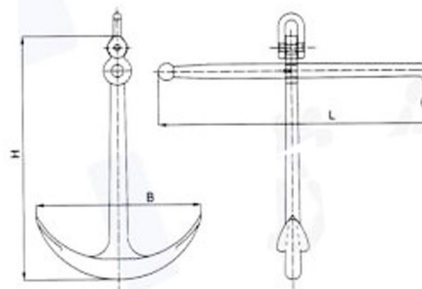

名义重量 NOMINAL WEIGHT (KG)	尺寸SIZE (mm)		
	H	L	B
500	2000	2065	1350
700	2260	2335	1510
750	2310	2342	1560
1000	2550	2637	1700
1500	2890	2960	1950
2000	3160	3272	2140
3000	3630	3555	2650
3500	3810	3820	2570
4000	4000	4135	2920
5000	4310	4470	3140
6000	4580	4740	3330
7000	4820	4980	3530
8000	5040	5215	3620

**美式(海军)无杆锚 CJ-14**  
U.S.N. (NAVY) STOCKLESS ANCHOR

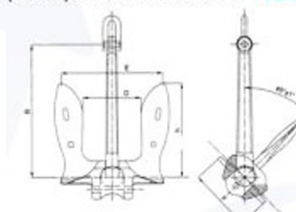

名义重量 NOMINAL WEIGHT (LBS)	尺寸SIZE (mm)				
	B	D	E	F	h
300	727	319	562	348	510
400	800	351	619	364	570
500	863	379	666	412	614
600	914	402	708	438	652
750	984	423	763	461	687
800	1008	443	778	483	710
1000	1071	477	839	520	773
1200	1152	507	892	532	822
1300	1184	521	926	567	844
1500	1244	546	962	596	883
1800	1320	580	1021	632	941
2000	1371	601	1058	655	975
2200	1412	621	1092	676	1006
2500	1473	648	1139	706	1050
3000	1564	704	1270	775	1090
3500	1641	725	1275	790	1175
4000	1724	758	1333	826	1228

名义重量 NOMINAL WEIGHT (LBS)	尺寸SIZE (mm)				
	B	D	E	F	h
5000	1884	816	1436	889	1323
6000	1974	867	1528	947	1403
7000	2082	913	1606	996	1480
8000	2171	955	1679	1040	1547
9000	2257	993	1747	1082	1609
10000	2336	1028	1809	1120	1667
11000	2413	1062	1868	1158	1721
12000	2486	1093	1924	1193	1771
13000	2540	1122	1965	1194	1819
14500	2641	1144	2047	1270	1887
15000	2679	1177	2089	1295	1908
16000	2735	1203	2116	1311	1950
18000	2844	1251	2200	1365	2028
20000	2946	1296	2280	1412	2100
22500	3060	1345	2370	1463	2134
25000	3174	1396	2456	1521	2262
30000	3371	1483	2628	1631	2404